



User Manual



•

•

•

•

•

•

•

•

•

-

-

-
-













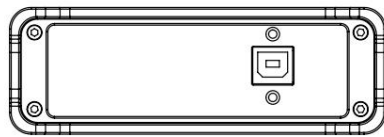

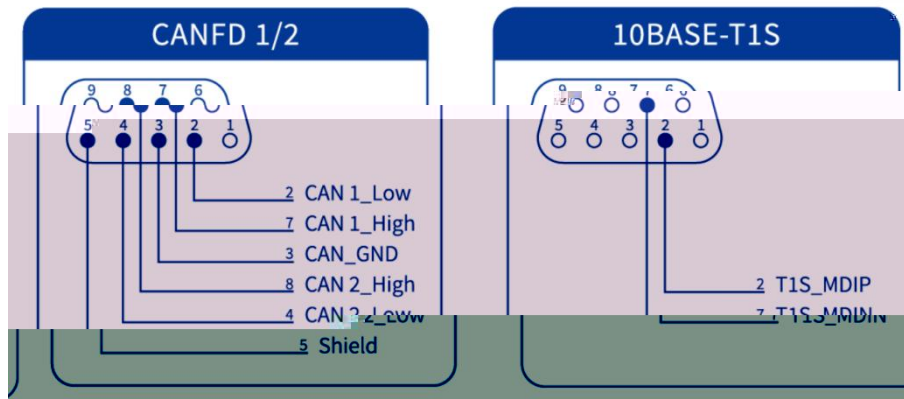













-
-
-



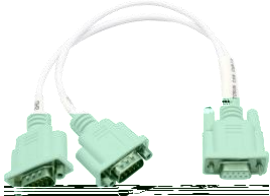

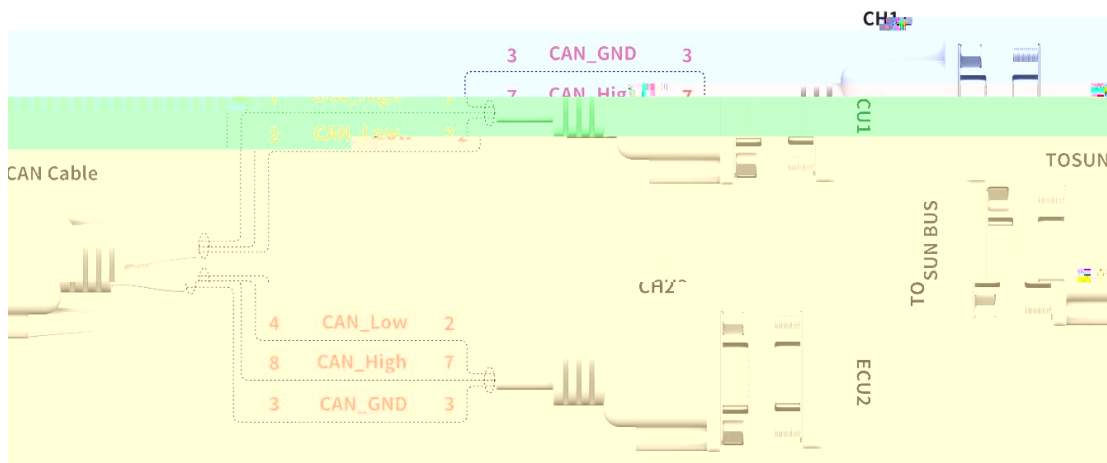
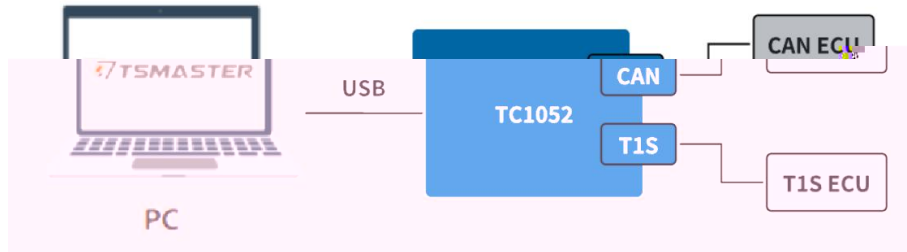

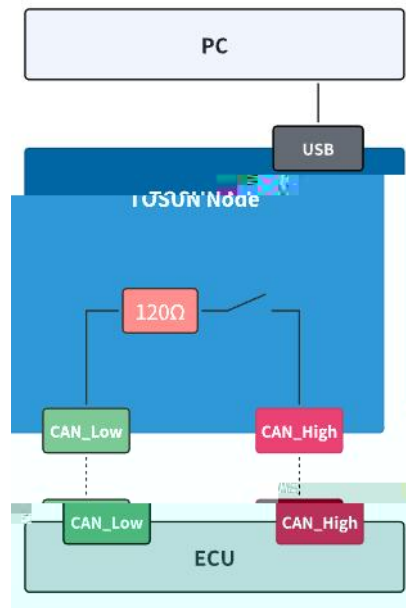

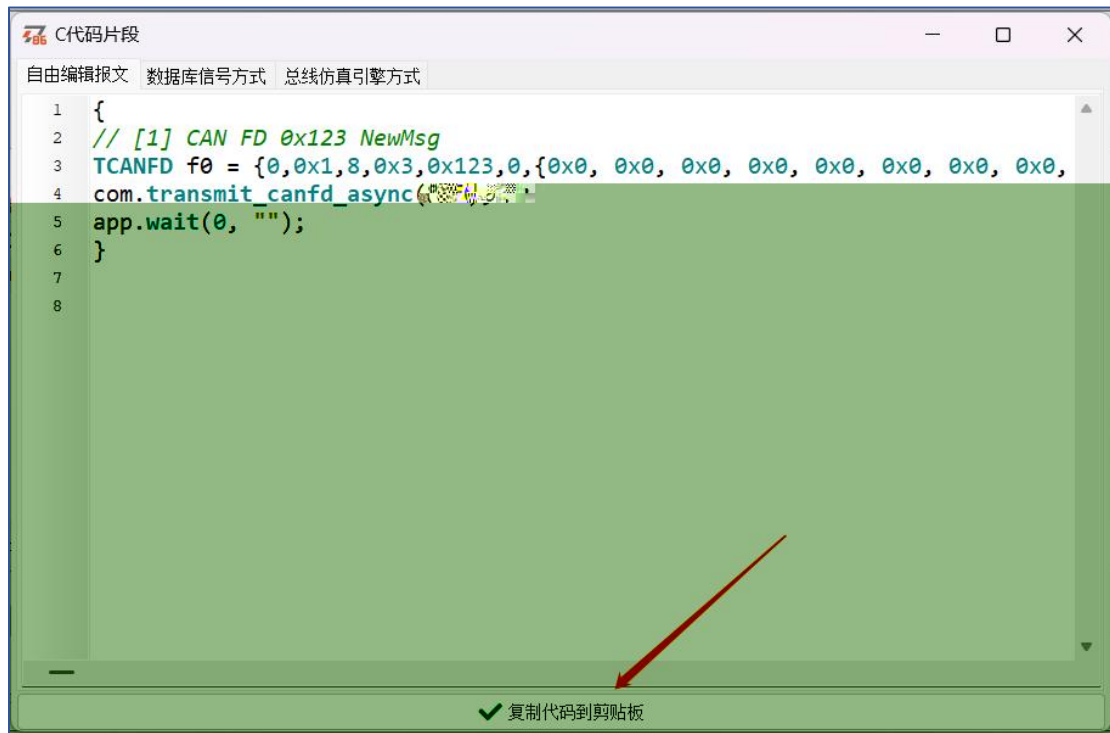

```
1 {
2 // [1] CAN FD 0x123 NewMsg
3 TCANFD f0 = {0,0x1,8,0x3,0x123,0,{0x0, 0x0, 0x0, 0x0, 0x0, 0x0, 0x0, 0x0},
4 com.transmit_canfd_async(
5 app.wait(0, "");
6 }
7
8
```

✓ 复制代码到剪贴板

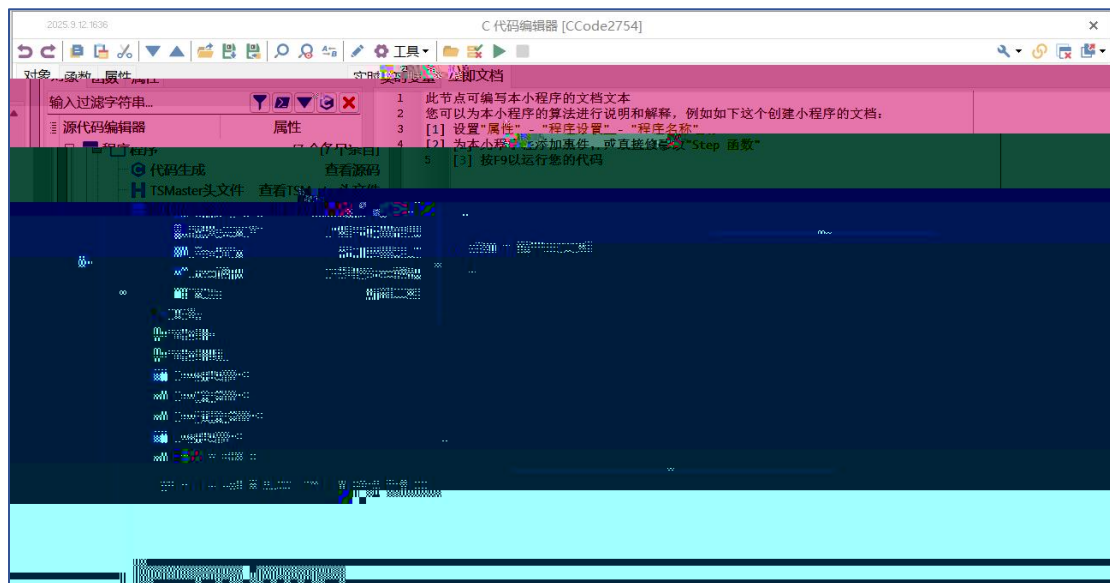

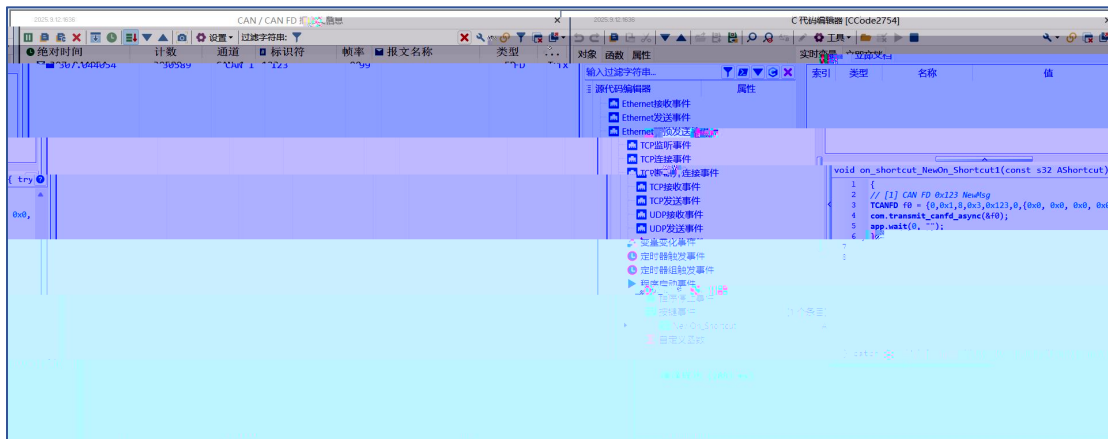
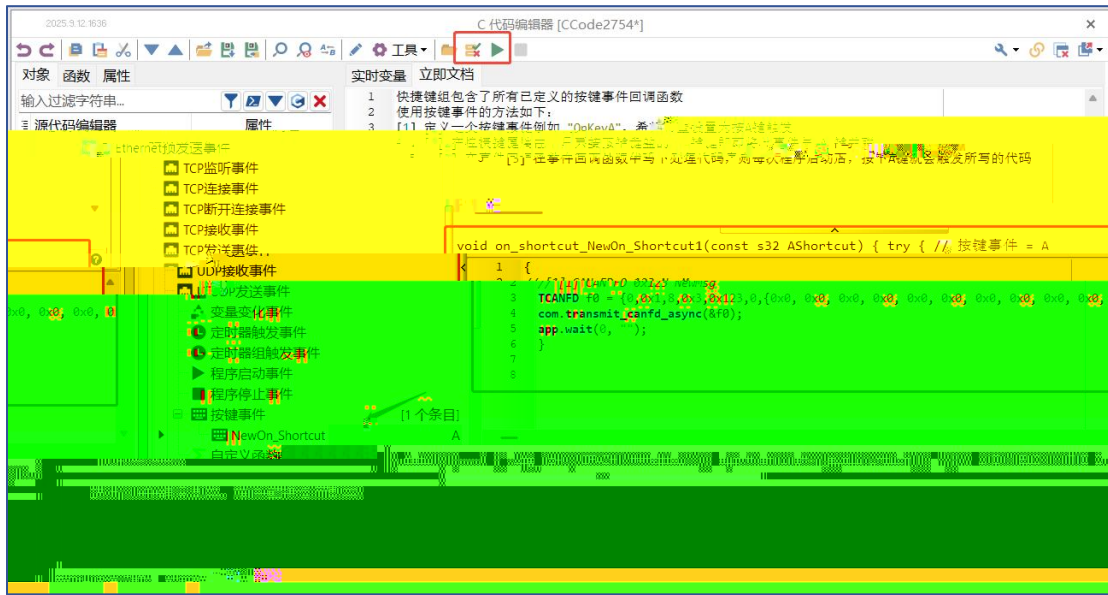

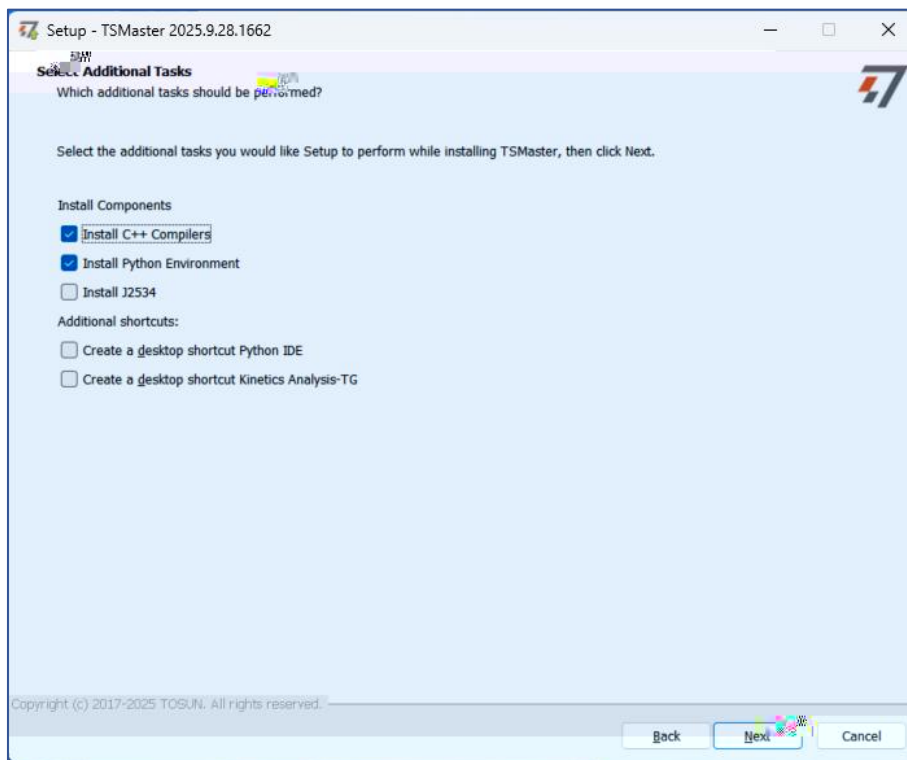
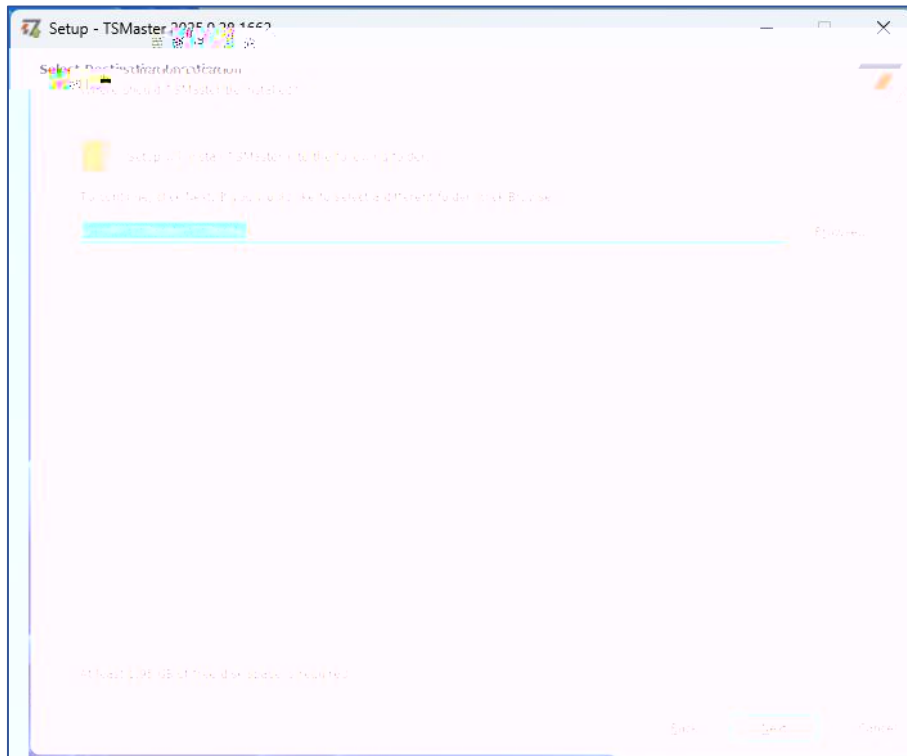

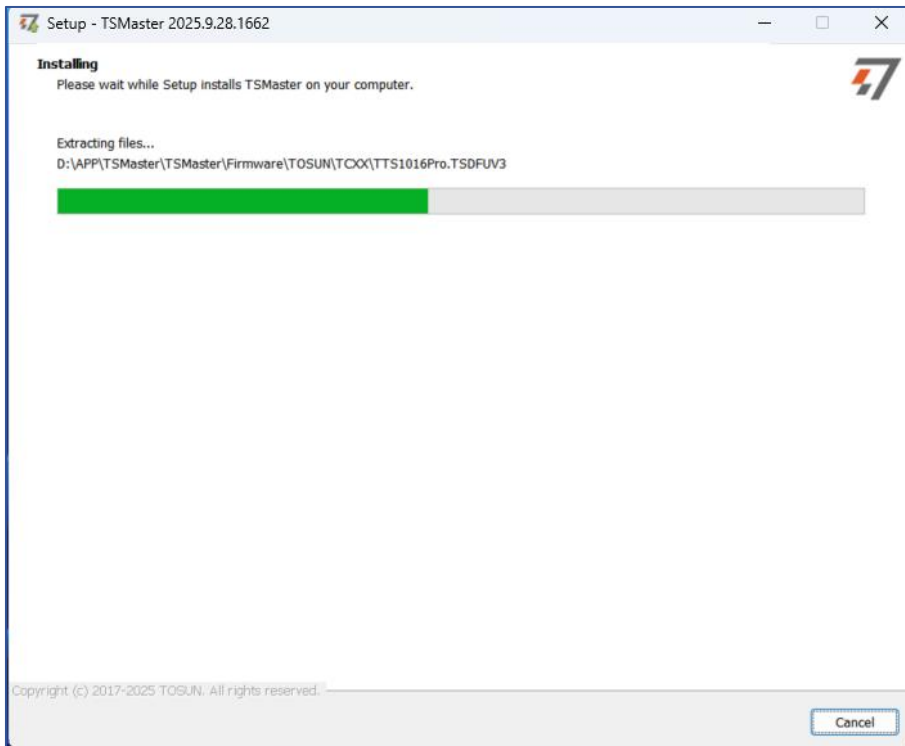
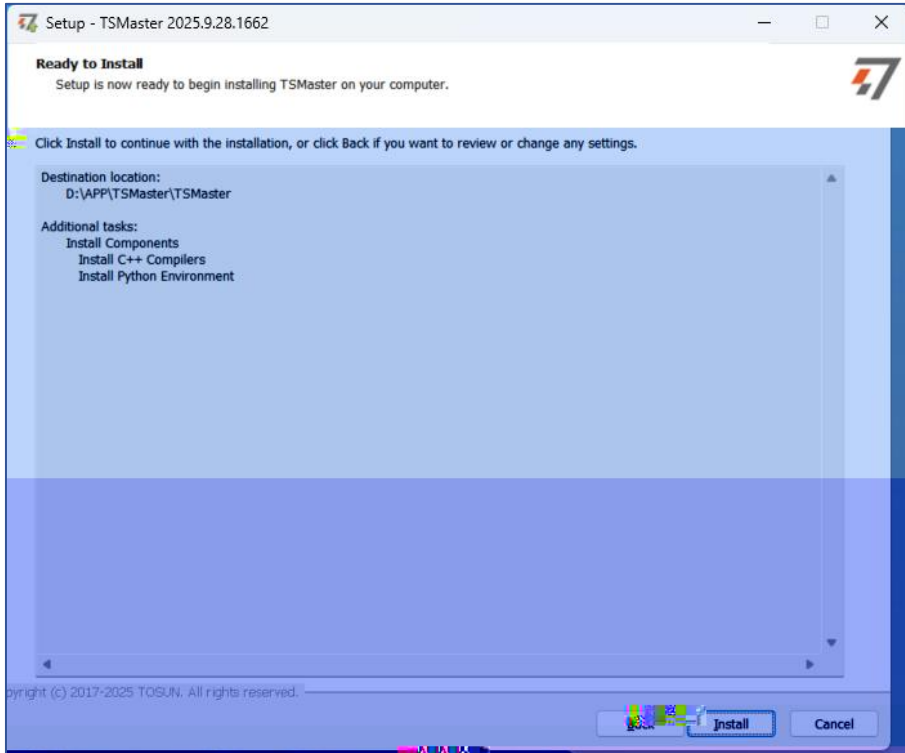





--	--	--	--





Software

Support CAN FD / LIN / FlexRay / SOME/IP / SAE J2279 and DoIP
 Support diagnostic / repair function / application calibration

Support programming / calibration / ECU
 of microcontroller
 like microcontroller / microcontroller

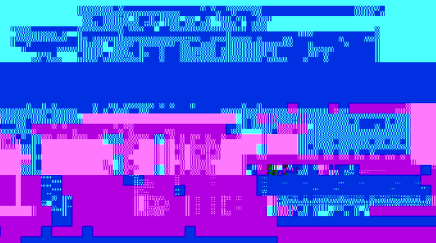

Hardware

Support CAN FD / LIN / FlexRay / SOME/IP / SAE J2279 and DoIP

- Network Automation Testing System
- Charging Testing System
- EMB Calibration Testing Equipment
- Information Security Solutions
- Steering Wheel Basis Testing Solutions

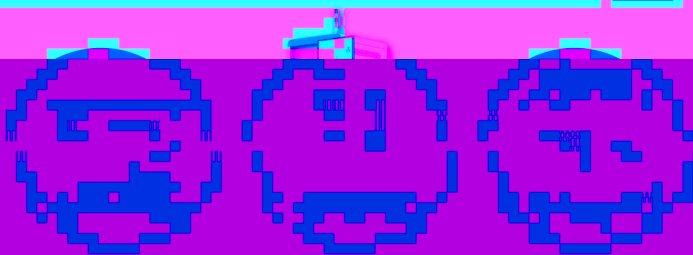

Hardware

1/2/4/8/12-channel CAN FD / CAN to USB / PCIe device
 Max 1000000 baud rate

Support CAN FD / LIN / FlexRay / SOME/IP / SAE J2279 and DoIP
 Support diagnostic / repair function / application calibration

Support CAN FD / LIN / FlexRay / SOME/IP / SAE J2279 and DoIP

Support diagnostic / repair function / application calibration

Support CAN FD / LIN / FlexRay / SOME/IP / SAE J2279 and DoIP

Support diagnostic / repair function / application calibration

Support CAN FD / LIN / FlexRay / SOME/IP / SAE J2279 and DoIP

Support diagnostic / repair function / application calibration



Hardware

Support CAN FD / LIN / FlexRay / SOME/IP / SAE J2279 and DoIP

R&D, testing, production, and after-sales. It integrates essential functions with hardware support to streamline processes and ensure precision, making it ideal for automotive professionals.

International Organization
ASAM **CiR**
 Quality Assurance



Support CAN FD / LIN / FlexRay / SOME/IP / SAE J2279 and DoIP
 Support diagnostic / repair function / application calibration

