

1

" "

Í m0-° 73 ' ?L†ø .

---

œM†#bB ý



**1.1.**

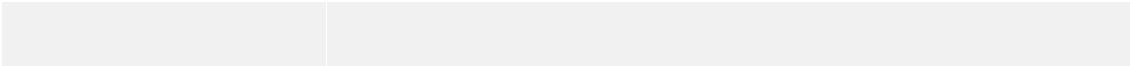

**1.2.**



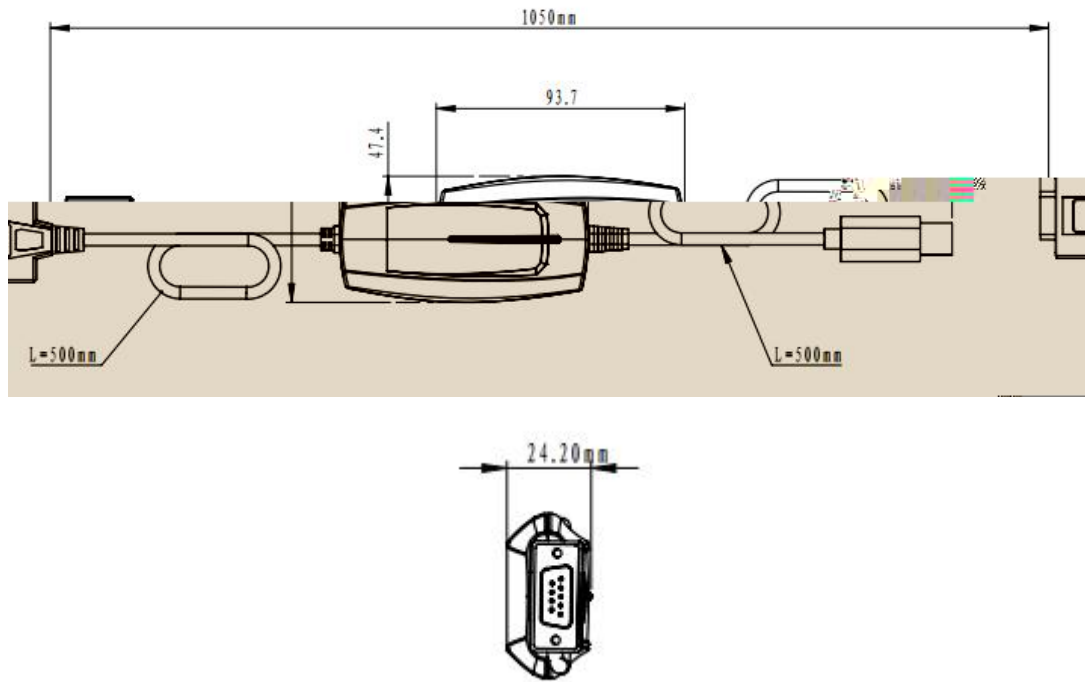

**1.3.**

**1.4.**

**LED**

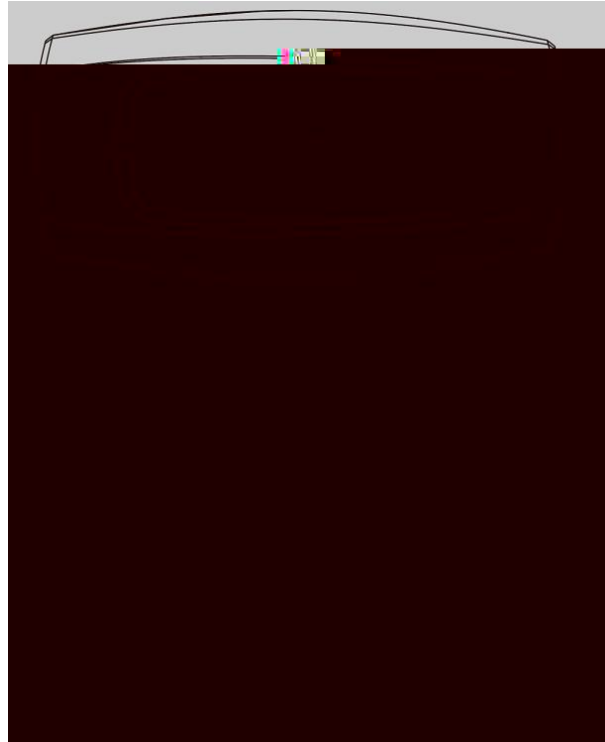





1.5.

**1.6.**

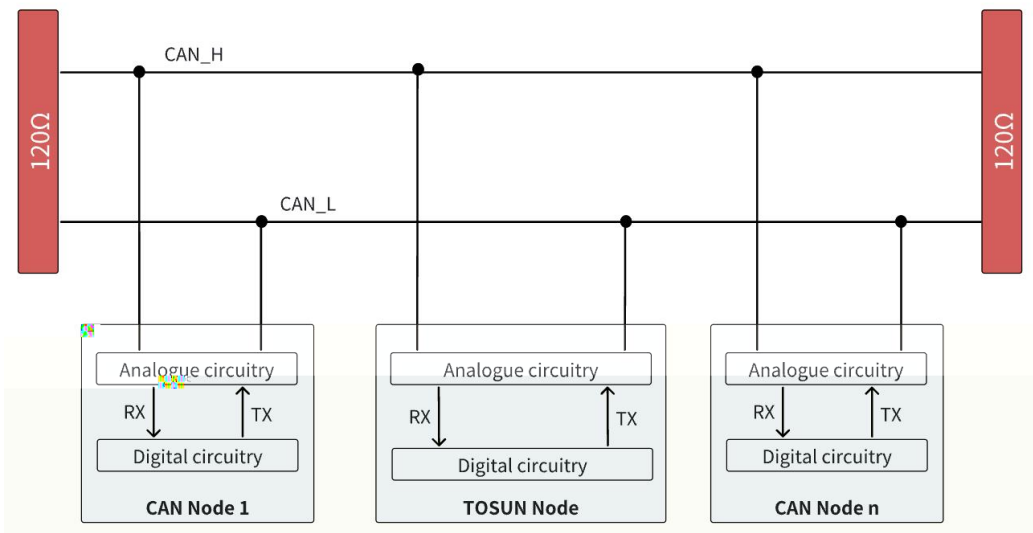
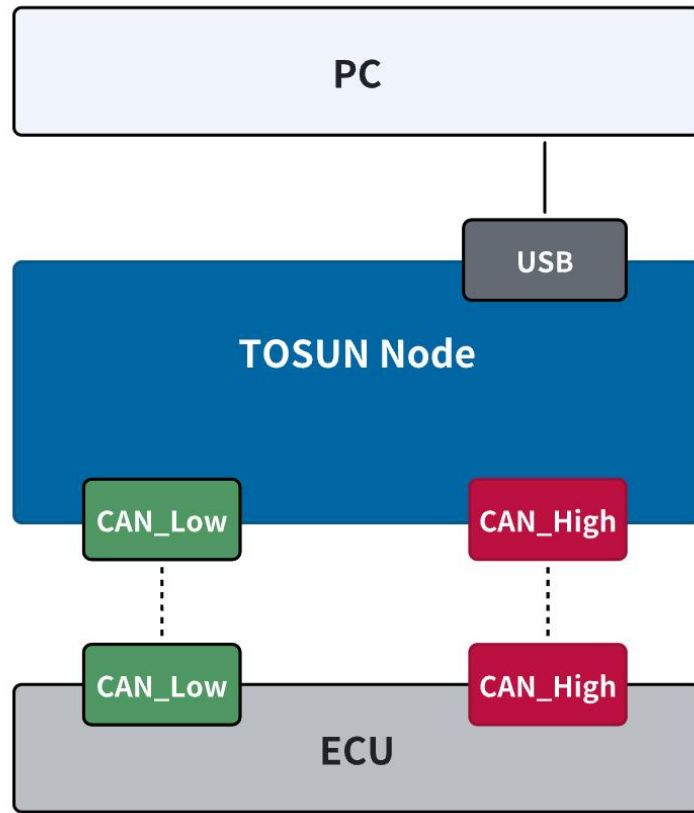

## 2.1.

```
tosun@tosun-HP-ProBook-455-15-6-inch-G9-Notebook-PC:~/Desktop/TC111/TC111/00_user$ ls
socket_can.c  socket_drv.c  TOSUN-SOCKET_CAN使用指南_V1.0.0.docx  TOSUN-TC111用户手册_V1.0.0.docx
tosun@tosun-HP-ProBook-455-15-6-inch-G9-Notebook-PC:~/Desktop/TC111/TC111/00_user$
```

```
tosun@tosun-HP-ProBook-455-15-6-inch-G9-Notebook-PC:~/Desktop/TC111/TC111/00_user/socket_drv$ make
-e -----
-e  Checking build environment...
-e -----
# make
# sudo
# kernel build dir
# 必要头文件
# 必要源文件
-e  Using gcc-12, version 12
-e  Building kernel module tosun_socket_can.ko for 6.8.0-65-generic...
Using CC=gcc-12
make[1]: Entering directory '/usr/src/linux-headers-6.8.0-65-generic'
warning: the compiler differs from the one used to build the kernel
The kernel was built by: x86_64-linux-gnu-gcc-12 (Ubuntu 12.3.0-1ubuntu1~22.04) 12.3.0
You are using:      gcc-12 (Ubuntu 12.3.0-1ubuntu1~22.04) 12.3.0
CC [M] /home/tosun/Desktop/TC111/TC111/00_user/socket_drv/drivers/net/usb/tosun_socket_can.o
...

```





TC111

6 1 1



