





1.1.



1.2.

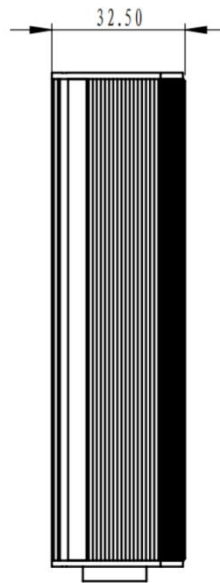
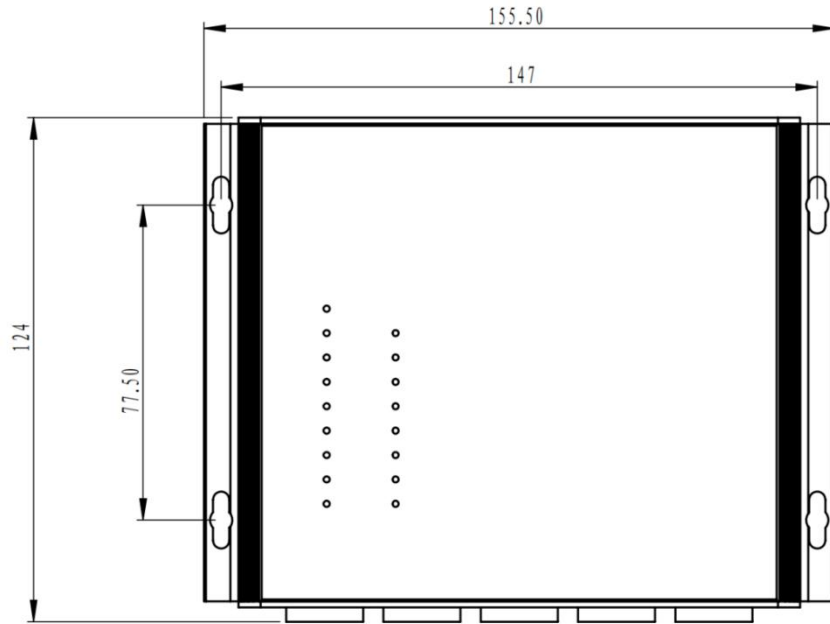

1.3.

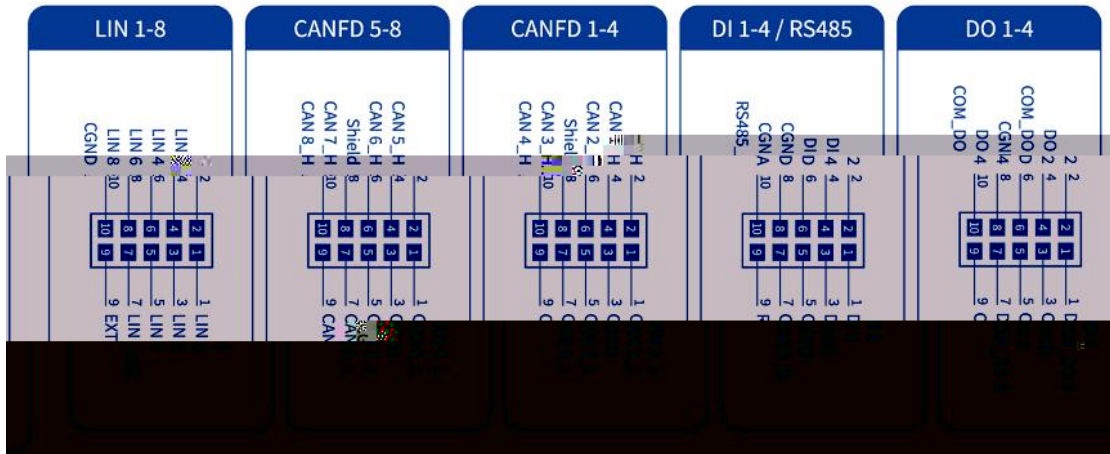
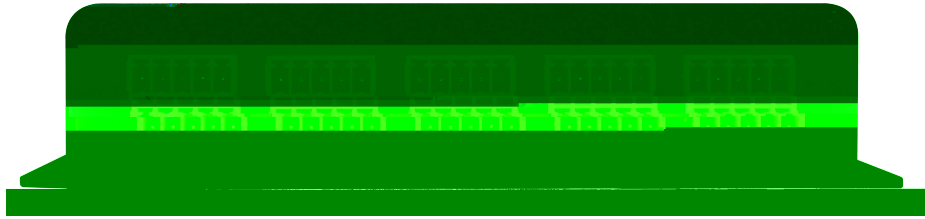

1.4. LED

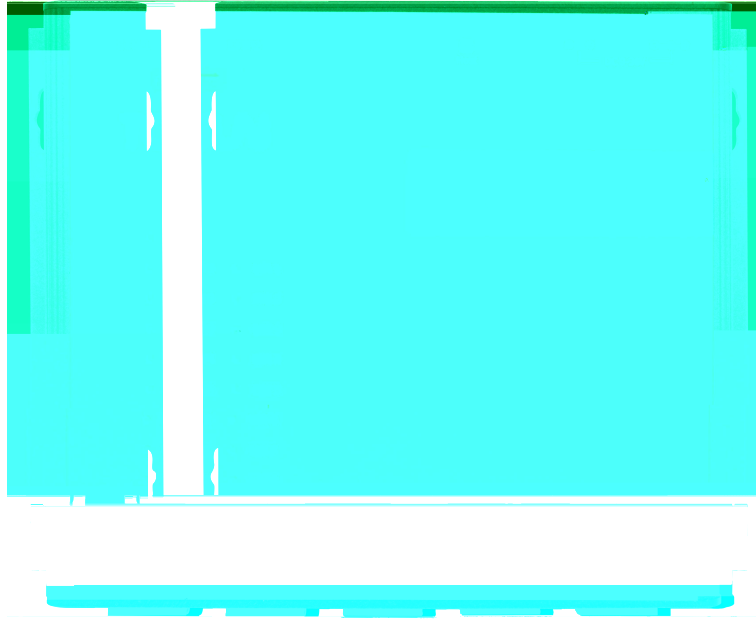

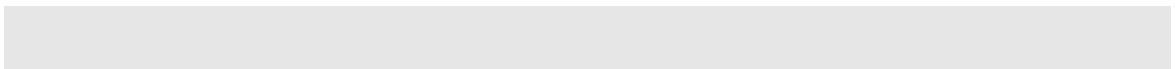





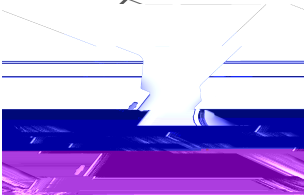

1.5.

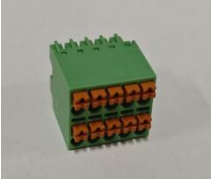

1.6.

			
			
			
		<p>国标 </p> <p>美规 </p> <p>欧规 </p>	
			

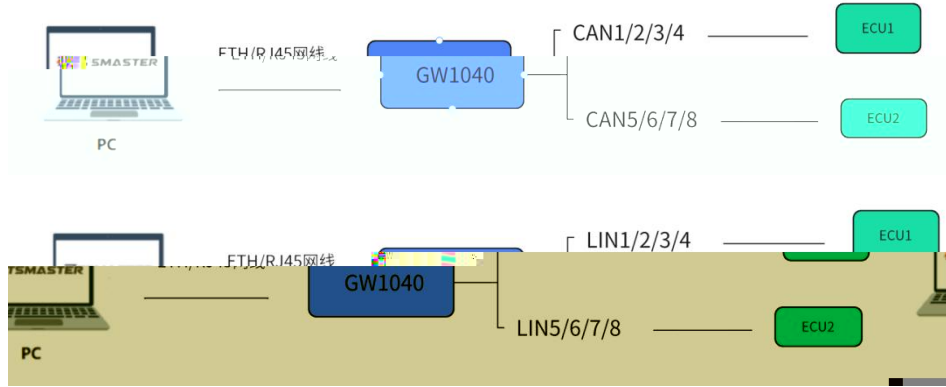

2.1.

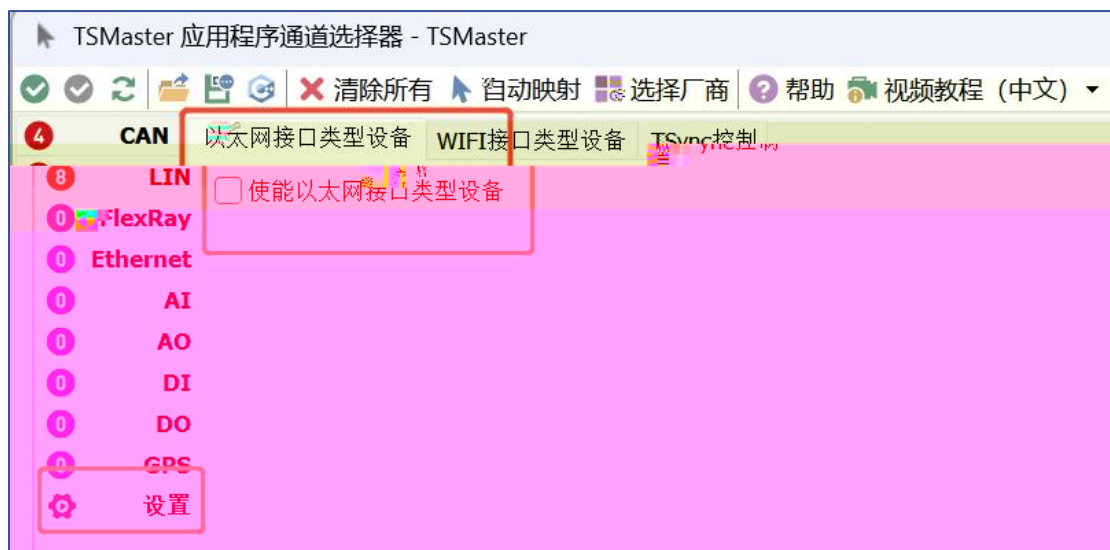

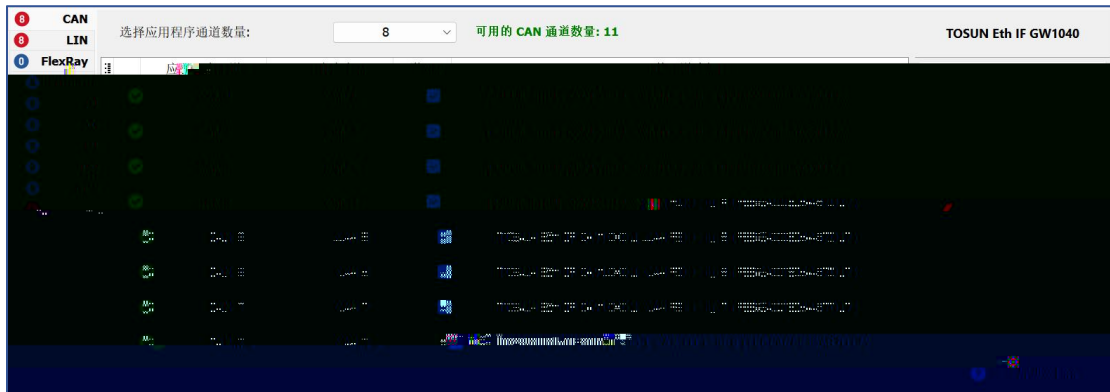

2.2.

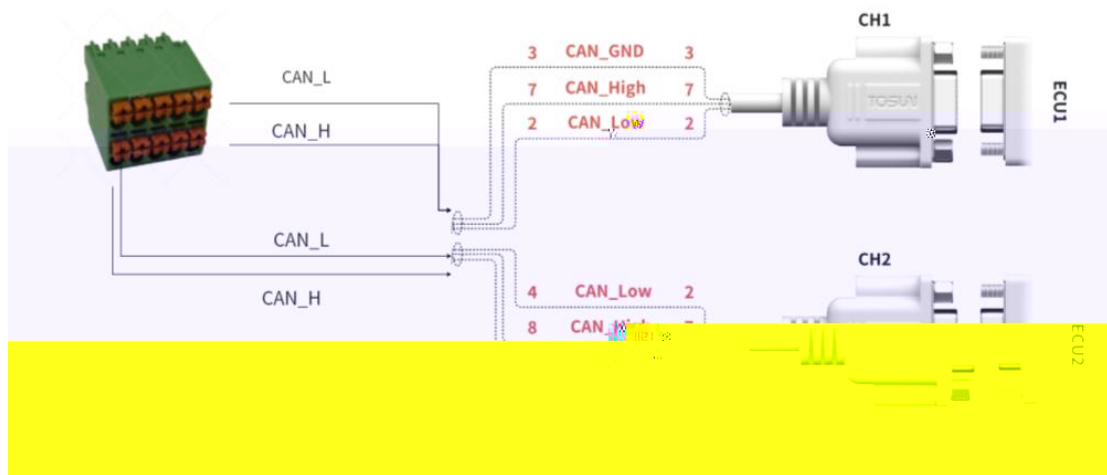

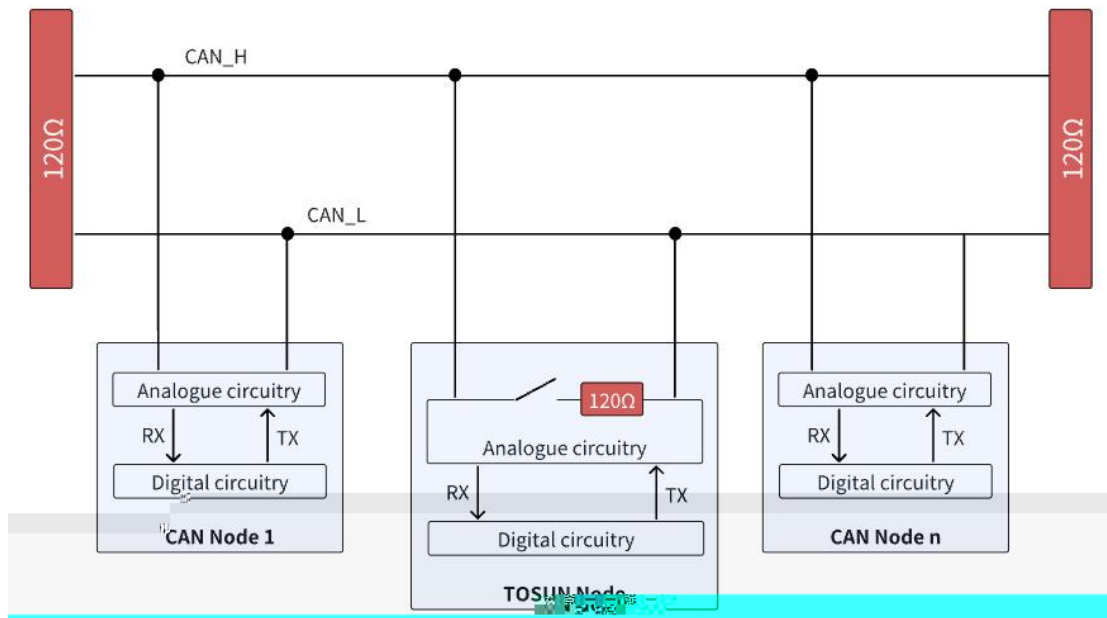
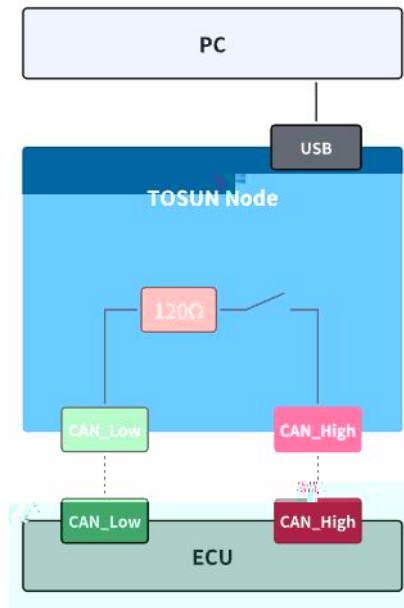

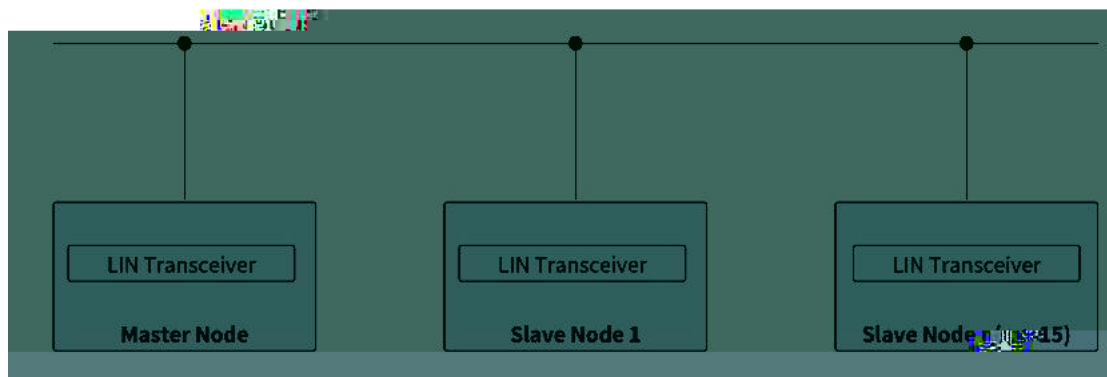
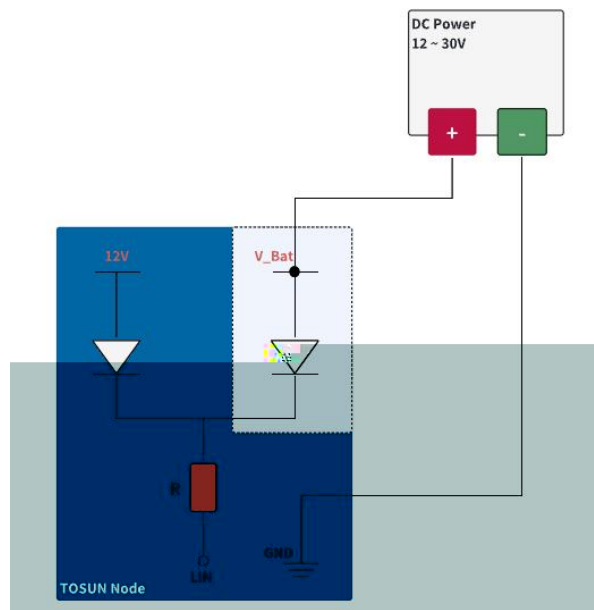

2.3.





统计信息		通道 1
通道波特率 [Kbps]		500
总线负载率 [%]		1.13
峰值负载率 [%]		1.14
标准数据帧率 [帧/每秒]		99
标准数据帧计数		4909
扩展数据帧率 [帧/每秒]		0
扩展数据帧计数		0
标准远程帧率 [帧/每秒]		0
标准远程帧计数		0
扩展远程帧率 [帧/每秒]		0
扩展远程帧计数		0
错误帧率 [帧/每秒]		0
错误帧计数		0
控制器状态		错误主动
发送错误计数		95

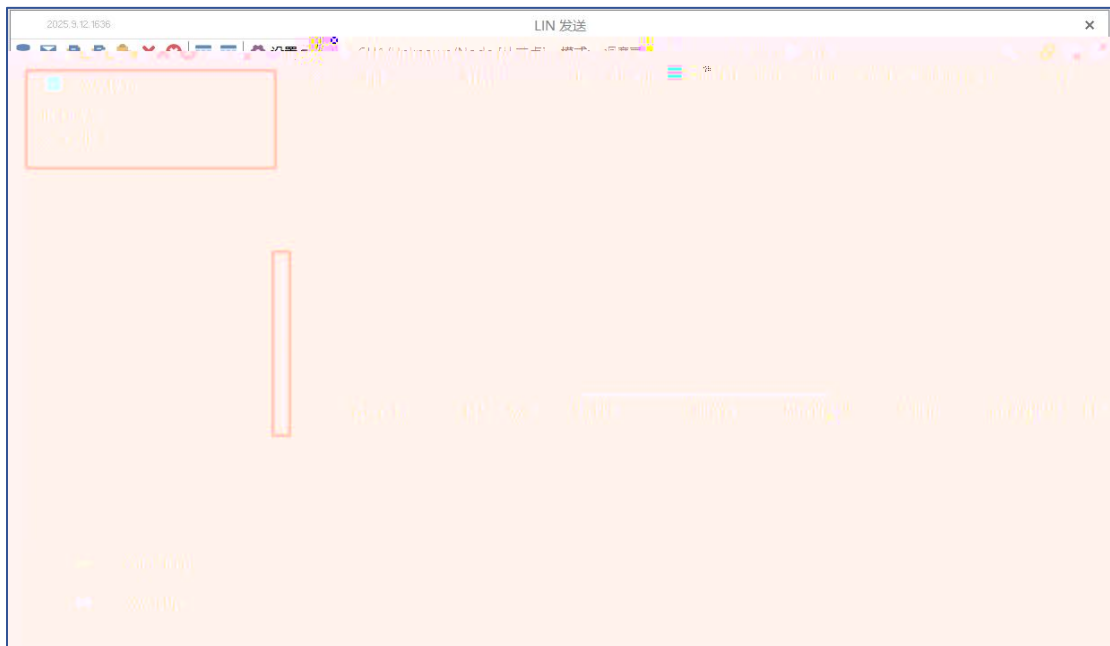
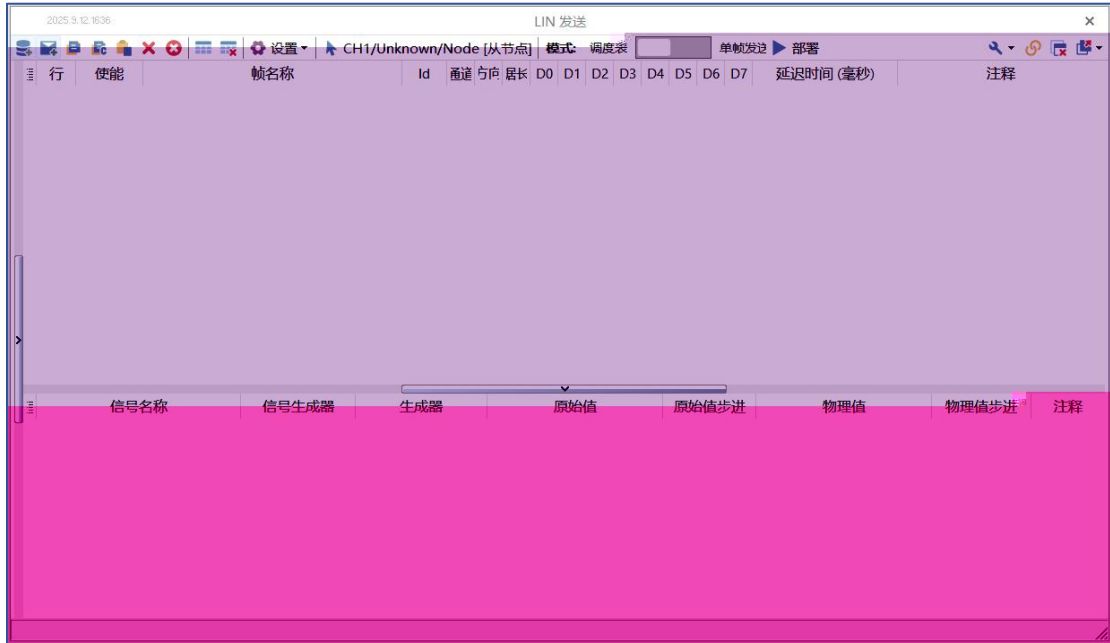

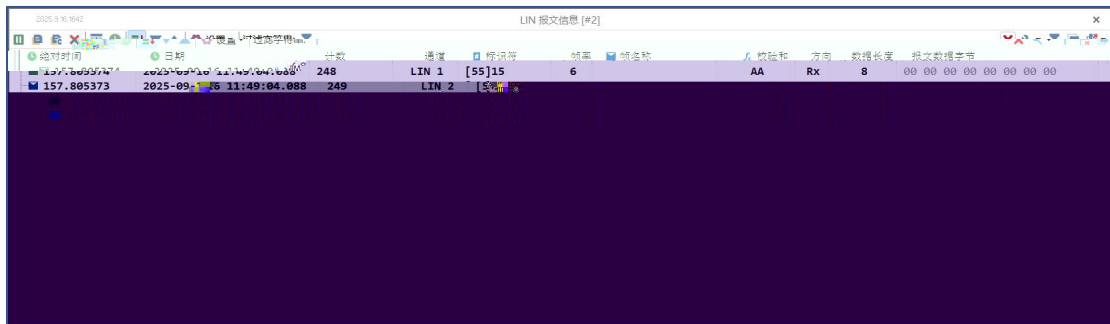

3.1.

